

OPERATOR-PARTS MANUAL

4-GALLON PORTABLE AIR COMPRESSOR

Questions, problems, missing parts? Before returning to the store, call Customer Service
8 a.m. - 6 p.m., EST, Monday - Friday

PRODUCT SERVICE:
888-895-4549



industrialaircontractor.com

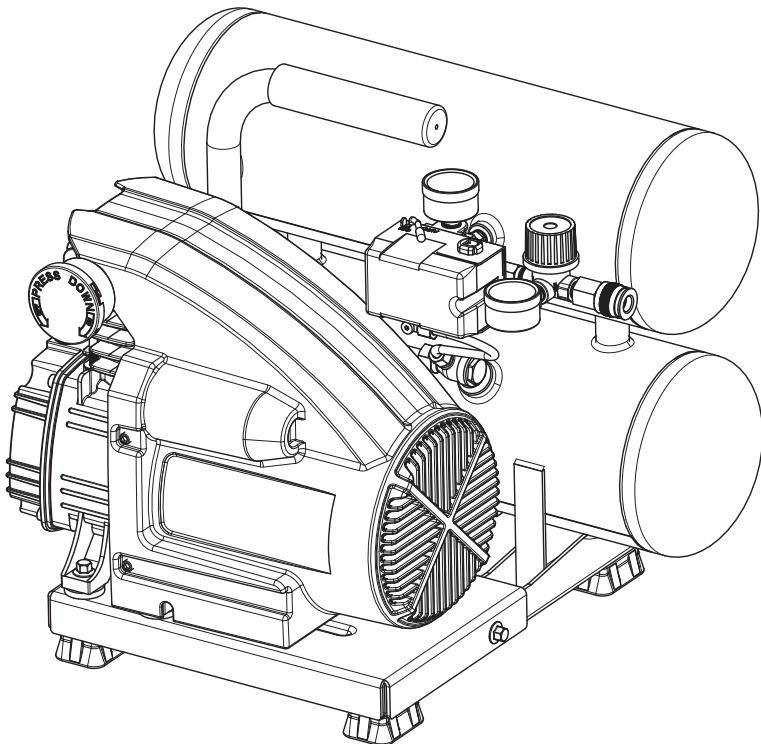

Table of Contents

Safety Information	2	Installing the Air Intake Filter	10
Work Area Safety	2	Installing the Fill Cap/Breather	11
Personal Safety	3	Refilling Compressor Pump with Oil	11
Moving the Compressor	3	Attaching the Hose	11
Air Compressor and Pneumatic Tool Safety	4	Tool Usage.....	12
Electrical Safety	5	Operation	13
Warranty	7	Maintenance	17
Pre-Operation	8	General Maintenance.....	17
Specifications	8	Lubrication	17
Duty Cycle	8	Cleaning the Air Filter	17
Package Contents	8	Changing the Oil	18
System Components	9	Care and Cleaning	18
Placement of the Air Compressor	10	Troubleshooting	19
		Service Parts	21

Safety Information

This manual contains information that is important for you to know and understand. This information relates to protecting your safety and preventing equipment problems. To help you recognize this information, we use the symbols below. Please read the manual and pay attention to these symbols.



DANGER: Indicates an imminently hazardous situation which, if not avoided, will result in death or serious injury.



WARNING: Indicates a potentially hazardous situation which, if not avoided, could result in death or serious injury.



CAUTION: Indicates a potentially hazardous situation which, if not avoided, may result in minor or moderate injury.

NOTICE: Indicates a practice not related to personal injury which, if not avoided, may result in property damage.

WORK AREA SAFETY

- Keep your work area clean and well lit. Ensure floors are not slippery from wax or dust.
- Operate the air compressor in an open area at least 18 in. (0.5 m) away from any wall or object that could restrict the flow of fresh air to ventilation openings.



WARNING: Do not operate power tools in explosive atmospheres, such as in the presence of flammable liquids, gases, or dust. Power tools create sparks which may ignite the dust or fumes. Keep bystanders, children, and visitors away while operating tools. Distractions can cause you to lose control.



WARNING: This compressor is not equipped for, and should not be used to supply breathing air. Additional equipment would be necessary to properly filter and purify the air to meet minimal specifications for Grade D breathing as described in Compressed Gas Association Commodity, Specification G 7.1 - 1966, OSHA 29 CF9 1910.134. Compressed Gas Association, 4221 Walney Road, Fifth Floor, Chantilly, VA 20151-2923, (703) 788-2700, www.cganet.com. Any such additional equipment has not been examined and no implication of proper use for breathing air is intended or implied.



CAUTION: Always disconnect the air supply and power supply before making adjustments, servicing a tool, or when a tool is not in use.

Safety Information (continued)

PERSONAL SAFETY

- Keep proper footing and balance at all times. Proper footing and balance enables better control of the tool in unexpected situations
- Do not use on a ladder or unstable support.



WARNING: Operating any power tool can result in foreign objects being thrown into your eyes, which can result in severe eye damage. Before beginning operation, always wear safety goggles, safety glasses with side shields, or a full face shield when needed. Always use eye protection marked to comply with ANSI Z87.1.



WARNING: This product contains chemicals known to the State of California to cause cancer and birth defects or other reproductive harm. Wash hands after handling.



WARNING: Use safety equipment. Always wear eye protection with side shields when operating power tools. A dusk mask, non-skid safety shoes, hard hat, or hearing protection must be used for appropriate conditions.



WARNING: Stay alert when operating a power tool. Do not use the tool while tired or under the influence of drugs, alcohol, or medication.



WARNING: Do not wear loose clothing or jewelry. Contain long hair. Keep your hair, clothing, and gloves away from moving parts. Loose clothes, jewelry, or long hair can be caught in moving parts.



WARNING: Never touch any exposed metal parts on compressor during or immediately after operation. The compressor will remain hot for several minutes after operation. Do not reach around protective shrouds or attempt maintenance until the unit has been allowed to cool.

MOVING THE AIR COMPRESSOR

- Grasp the handle.
- When the location is reached, slowly lower the compressor to the ground. Always store the compressor in a horizontal position resting on the rubber bumpers.
- When transporting the compressor in a vehicle, trailer, etc., make sure the tank is drained and the unit is secured with straps to prevent tipping. Use care when driving to prevent tipping the unit over in the vehicle. Damage can occur to the compressor or surrounding items if the compressor is tipped. Do not lift by the shroud.



WARNING: Risk of unsafe operation. Ensure proper footing and use caution when carrying the compressor so that the unit does not cause loss of balance.

Safety Information (continued)

AIR COMPRESSOR AND PNEUMATIC TOOL SAFETY

- Keep compressors as far from the spraying area as possible: at least 15 ft. (4.6 m) from the spraying area and all explosive vapors.
- If connected to a circuit protected by fuses, use time-delay fuses with this product.
- Ensure the hose is free of obstructions or snags. Entangled or snarled hoses can cause loss of balance or footing, and may become damaged.
- Use the air compressor only for its intended use. Do not alter or modify the unit from the original design or function. Never weld or drill holes in the air tank.
- Never leave a tool unattended with the air hose attached.
- Do not operate this tool if it does not contain a legible warning label.
- Do not continue to use a tool or hose that leaks air or does not function properly.
- Do not attempt to pull or carry the air compressor by the hose.
- Your tool may require more air consumption than this air compressor is capable of providing.
- Never direct a jet of compressed air toward people or animals.
- Protect your lungs. Wear a face or dust mask if the operation is dusty.
- Do not use this air compressor to spray chemicals. Your lungs can be damaged by inhaling toxic fumes. A respirator may be necessary in dusty environments or when spraying paint.
- This compressor is equipped with a thermal overload protector which will shut off the motor if it becomes overheated.



WARNING: Do not attempt to modify this tool or create accessories not recommended for use with this tool. Any such alteration or modification is misuse and could result in a hazardous condition leading to possible serious personal injury.



CAUTION: Do not use the compressor in an environment that is dusty or otherwise contaminated. Using the air compressor in this type of environment may cause damage to the unit.



CAUTION: Risk of bursting. Do not adjust the regulator to result in output pressure greater than the marked maximum pressure of the attachment. Do not use at pressure greater than the rated maximum pressure of this compressor.



CAUTION: To reduce the risk of electric shock, do not expose the compressor to rain. Store indoors.

Safety Information (continued)

ELECTRICAL SAFETY (EXTENSION CORDS)

- Use only 3-wire extension cords that have 3-prong grounding plugs and 3-port grounded receptacles that accept the product's plug. When using a power tool at a considerable distance from the power source, use an extension cord heavy enough to carry the current that the product will draw. An undersized extension cord will cause a drop in line voltage, resulting in a loss of power and causing the motor to overheat.
- Use the chart provided below to determine the minimum wire size required in an extension cord. Only round jacketed cords listed by Underwriter's Laboratories (UL) should be used.
- Only use 50 ft. or less, round jacketed cords listed by Underwriter's Laboratories (UL).
- When operating a power tool outside, use an outdoor extension cord marked "W-A" or "W". These cords are rated for outdoor use and reduce the risk of electric shock.

Ampere rating (on air compressor data plate)	
	12 - 14
Cord Length	Wire Size (AWG)
25 ft.	NR
50 ft.	12
Used on 12 gauge - 20 amp circuit.	
NOTE: AWG=American Wire Gauge	

ELECTRICAL SAFETY (ELECTRICAL CONNECTION)

This air compressor is powered by a precision built electric motor. It should be connected to a power supply that is 120 volts, 60 Hz, AC only (normal household current).

- Do not operate this tool on direct current (DC). A substantial voltage drop will cause a loss of power and the motor will overheat. If the air compressor does not operate when plugged into an outlet, double check the power supply.



WARNING: When using an extension cord, keep it clear of the working area. Position the cord so that it will not get caught on lumber, tools, or other obstructions while you are working with a power tool. Failure to do so can result in serious personal injury.



WARNING: Check extension cords before each use. If damaged, replace immediately. Never use the air compressor with a damaged cord since touching the damaged area could cause electrical shock resulting in serious personal injury.



WARNING: Improperly connecting the equipment-grounding conductor can result in a risk of electrical shock.



CAUTION: Avoid body contact with grounded surfaces such as pipes, radiators, ranges, and refrigerators. There is an increased risk of electric shock if your body is grounded.



CAUTION: Do not expose power tools to rain or wet conditions. Water entering a power tool will increase the risk of electric shock.



CAUTION: Replace damaged cords/wiring immediately. Damaged cords/wiring increase the risk of electric shock.

NOTICE: Use longer air hoses instead of long extension cords. Your air compressor will run better and last longer.

Safety Information (continued)

ELECTRICAL SAFETY (SPEED AND WIRING)

- The no-load speed of this product is approximately 3,450 rpm. This speed is not constant and decreases under a load or with lower voltage.
- For voltage, the wiring in a shop is as important as the motor's horsepower rating. A line intended only for lights cannot properly carry a power tool motor. Wire that is heavy enough for a short distance will be too light for a greater distance. A line that can support one power tool may not be able to support two or three products.

ELECTRICAL SAFETY (GROUNDING INSTRUCTIONS)

- This product must be grounded. In the event of an electrical short circuit, grounding reduces the risk of electric shock by providing an escape wire for the electric current. This product is equipped with a cord having a grounding wire with an appropriate grounding plug. The plug must be plugged into an outlet that is properly installed and grounded in accordance with all local codes and ordinances.



WARNING: Improper installation of the grounding plug may result in a risk of electric shock. When repair or replacement of the cord or plug is required, do not connect the grounding wire to either flat blade terminal. The wire with insulation having an outer surface that is green with or without yellow stripes is the grounding wire.

- Check with a qualified electrician or service personnel if these instructions are not completely understood or if in doubt as to whether the tool is properly grounded.
- Do not modify the plug provided; if it will not fit the outlet, have the proper outlet installed by a qualified electrician.
- This product is for use on a nominal 120-Volt circuit and has a grounding plug similar to the plug shown. Only connect the product to an outlet having the same configuration as the plug. Do not use an adapter with this product.

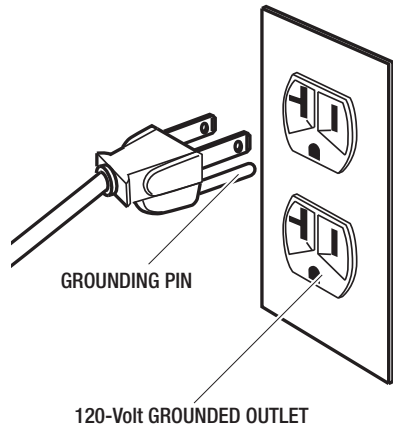

Warranty

ONE YEAR LIMITED WARRANTY

What Does This Warranty Cover? MAT Industries, LLC. (the Company) warrants from the date of purchase by the original retail purchaser only, parts and labor to remedy substantial defects found in materials, or workmanship.

How Long Does The Coverage Last? The duration of this warranty is One Year. This warranty is not transferable to subsequent owners.

What MAT Industries Will Do? MAT Industries, LLC. will cover parts and labor to remedy substantial defects due to materials and workmanship during the first year of ownership, with the exceptions noted below, and parts only, to remedy substantial defects due to material and workmanship for the remaining term of coverage with the exceptions noted below. Parts used in repair of whole goods or accessories are warranted for the balance of the original warranty period.

What is Not Covered Under This Warranty? Failure by the original retail purchaser to install, maintain, and operate said equipment in accordance with standard industry practices. Modifications to the product, or tampering with components, or failure to comply with the specific recommendations of the Company set forth in the owner's manual, will render this warranty null and void.

The Company shall not be liable for any repairs, replacements, or adjustments to the equipment, or any costs for labor performed by the purchaser without the Company's prior written approval. The effects of corrosion, erosion, surrounding environmental conditions, cosmetic defects, and routine maintenance items, are specifically excluded from this warranty. Routine maintenance items such as: oil, lubricants, and air filters, as well as changing oil, air filters, belt tensioning, etc... fall under the owner's responsibility. Additional exclusions include: freight damage, failures resulting from neglect, accident, or abuse, induction motors when operated from a generator, oil leaks, air leaks, oil consumption, leaky fittings, hoses, petcocks, bleeder tubes, and transfer tubes.

- If the compressor is used for commercial, industrial, or military applications, the warranty will apply for 90 days from the date of purchase. Two stage compressors are not limited to a 90 day warranty when used in commercial or industrial applications.
- Rental applications render this warranty null and void.
- Labor, service calls, and travel charges, are not covered after the first year of ownership on stationary compressors (compressors without handles, or wheels). Repairs requiring overtime, weekend rates, or any other charges beyond the standard shop labor rate are not covered.
- Time required for orientation training for the service center to gain access to the product, or additional time due to inadequate egress.
- Damage caused by incorrect voltage, improperly wired, or failure to have a certified licensed electrician install the compressor, will render this warranty null and void.
- Damage caused from inadequate filter maintenance.
- Pump wear or valve damage caused by using oil not specified.
- Pump wear or damage caused by any oil contamination.
- Pump wear or valve damage caused by failure to follow proper maintenance guidelines.
- Operation below proper oil level or operation without oil.
- Gas Engines, if product is equipped with a gas engine, see engine manual for specific engine manufacturer's warranty coverage.

Parts purchased separately: The warranty for parts purchased separately such as: pumps, motors, etc., are as follows:

From Date of Purchase

- All single & two stage pumps: 1 year
- Electric motors: 90 days
- Universal motor/pump: 30 days
- All other parts: 30 days
- No return authorization will be issued for electrical components once items are installed.

How do You Get Service? In order to be eligible for service under this warranty you must be the original retail purchaser, and provide proof of purchase from one of MAT Industries dealers, distributors, or retail outlet stores. Portable compressors or components must be delivered, or shipped, to the nearest Authorized MAT Industries Service Center. All associated freight costs and travel charges must be borne by the consumer. Please call our toll free number 1-888-895-4549 for assistance.

THIS WARRANTY GIVES YOU SPECIFIC LEGAL RIGHTS, AND YOU MAY ALSO HAVE OTHER RIGHTS WHICH VARY FROM STATE TO STATE. THE COMPANY MAKES NO OTHER WARRANTY OR REPRESENTATION OF ANY KIND WHATSOEVER, EXPRESSED OR IMPLIED, EXCEPT THAT OF TITLE. ALL IMPLIED WARRANTIES, INCLUDING ANY WARRANTY OF MERCHANTABILITY AND FITNESS FOR PARTICULAR PURPOSE ARE HEREBY DISCLAIMED. LIABILITY FOR CONSEQUENTIAL AND INCIDENTAL DAMAGES UNDER ANY AND ALL WARRANTIES, OTHER CONTRACTS, NEGLIGENCE, OR OTHER TORTS IS EXCLUDED TO THE EXTENT EXCLUSION IS PERMITTED BY LAW.

MAT Industries, LLC, Jackson, TN 38301 U.S.A.

Pre-Operation

SPECIFICATIONS

Running horsepower	1.5 HP
Air tank capacity	4 gal.
Air pressure	135 psi max.
Air delivery	4.5 SCFM at 40 psi 3.8 SCFM at 90 psi
Tank fill time	75 seconds
Lubrication	Oil lubricated
Input	120V, 60 Hz, Single phase AC only, 14.0 Amps.
Minimum branch circuit requirement	15 A
Fuse type	Time delay
Net weight	66 lbs.

DUTY CYCLE

This air compressor pump is capable of running continuously. However, to prolong the life of your air compressor, it is recommended that a 50% average duty cycle be maintained; that is, the air compressor pump should not run more than 30 minutes in any given hour.

PACKAGE CONTENTS

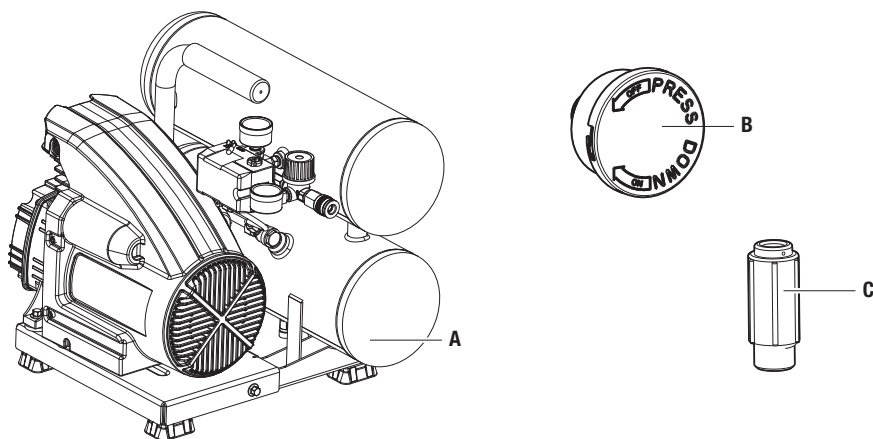

Part	Description	Quantity
A	Air Compressor Unit	1
B	Air Intake Filter	1
C	Fill Cap/Breather	1

Pre-Operation (continued)

SYSTEM COMPONENTS

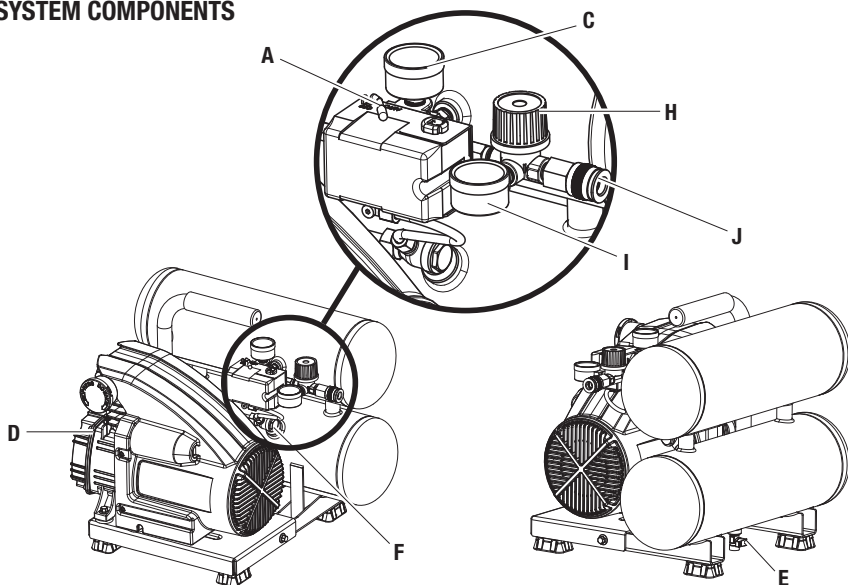

Part	Description
A	AUTO/OFF Switch: Turn this switch in the "AUTO (1)" position to provide automatic power to the pressure switch and "OFF (0)" to remove power at the end of each use.
B	Safety Valve: (not shown) If the pressure switch does not shut off the air compressor at its "cut-out" pressure setting, the safety valve will protect against high pressure by "popping out" at its factory set pressure (slightly higher than the pressure switch "cut-out" setting).
C	Tank Pressure Gauge: The tank pressure gauge indicates the reserve air pressure in the tank.
D	Air Compressor Pump: Compresses air into the air tank. Working air is not available until the compressor has raised the air tank pressure above that required at the air outlet.
E	Drain Valve: The drain valve is located at the base of the air tank and is used to drain condensation at the end of each use.
F	Check Valve: When the air compressor is operating, the check valve is "open", allowing compressed air to enter the air tank. When the air compressor reaches "cut-out" pressure, the check valve "closes", allowing air pressure to remain inside the air tank.
G	Thermal Overload Reset: (not shown) This motor has an automatic thermal overload protector. If the motor overheats for any reason, the overload protector will shut off the motor. The motor must be allowed to cool down before restarting. To restart: <ol style="list-style-type: none"> 1. Place the AUTO/OFF switch in the "OFF" (0) position and unplug the machine from its power source. 2. Allow the motor to cool. 3. Place the AUTO/OFF switch in the "AUTO" (1) position to restart the motor.
H	Regulator: Allows the user to adjust the pressure coming out of the tank to match what is needed for the task.
I	Pressure Regulator Gauge: Gauge that indicates the amount of pressure that the regulator is providing to the tool.
J	Quick Connect: Fitting that is designed to accept a hose that allows pressure to be released for tool usage.

Pre-Operation (continued)

PLACEMENT OF THE AIR COMPRESSOR



WARNING: If any parts are damaged or missing do not operate this product until the parts are replaced. Failure to heed this warning could result in serious personal injury.



CAUTION: Do not use in an environment that is dusty or otherwise contaminated. Using the air compressor in this type of environment may cause damage to the unit.



NOTE: Long lengths of electrical wiring could cause power loss to the motor.

- Place the air compressor in a clean, dry, and well ventilated area.
- The air compressor must be positioned at least 18 in. (0.5 m) away from the wall or other obstructions that will interfere with the flow of air.
- Locate the air compressor as close to the main power supply as possible to avoid using long lengths of electrical wiring.
- The air filter must be kept clear of obstructions which could reduce air flow to the air compressor.

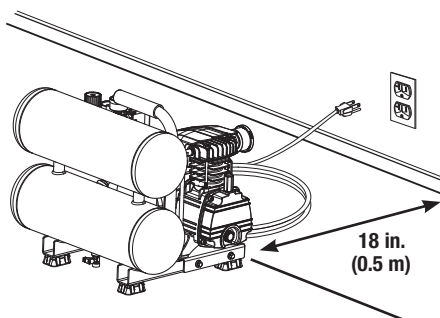

INSTALLING THE AIR INTAKE FILTER



CAUTION: Do not attempt to start the air compressor without first installing air intake filter and the fill cap/breather. The pump is shipped with oil from the factory, but pump can build internal pressure and blow off cap, if breather is not installed. Only use non-detergent oils when refilling, because the multi-viscosity motor oils leave carbon deposits on pump components, thus reducing the performance and compressor life.

- Remove the plastic plug (1) from the compressor head (2). Remove the air intake filter (3) from the poly bag and thread it into the compressor head (2), as shown.

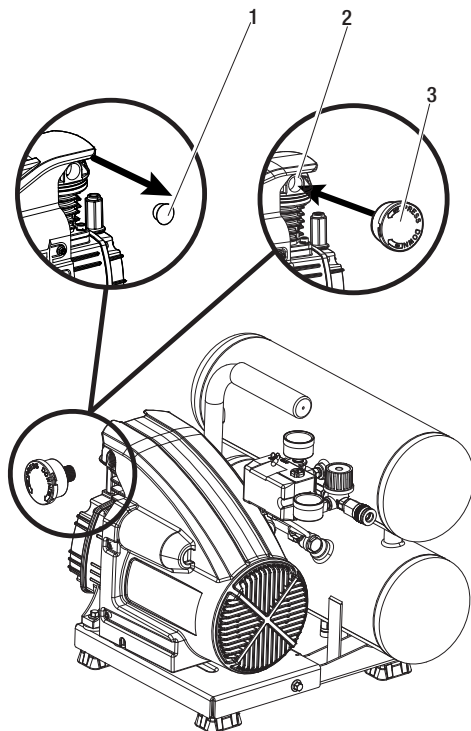

Pre-Operation (continued)

INSTALLING FILL CAP/BREATHER

- Compressor pump is filled with high quality oil at the factory. Remove the plug (4) from the oil fill port. Install the provided fill cap/breather (5) into the oil fill port.

REFILLING THE COMPRESSOR PUMP WITH OIL



WARNING: Drain the tank to release all the tank air pressure before removing the oil fill cap. Be sure the air vent in the oil fill cap is free from debris. If the air vent is blocked, pressure can build in the crankcase, causing damage to the compressor and possible personal injury.

- Remove the oil fill cap/breather (6) by turning it counter-clockwise by hand. Fill the compressor pump with air compressor oil, such as SAE-30 non-detergent Semi Synthetic oil, at slow intervals until the oil reaches the center of the red circle in the sight glass (7). Use SAE-10 during extreme winter conditions.

ATTACHING THE HOSE



WARNING: Do not attempt to modify this product or create accessories not recommended for use with this product. Any such alteration or modification is misuse and could result in a hazardous condition leading to possible serious personal injury.



WARNING: Do not attach the air chuck or other tools to the open end of the hose until start-up has been completed.



WARNING: Do not allow familiarity with products to make you careless. Remember that a careless fraction of a second is sufficient to inflict serious injury.



WARNING: Always wear safety goggles or safety glasses with side shields when operating power tools. Failure to do so could result in objects being thrown into your eyes resulting in possible serious injury.

The compressor is assembled at the factory and ready for use. Check all components to ensure secure assembly, (such as rubber feet, handle, quick connects, gages, safety valve, air filter, drain valve, etc.)



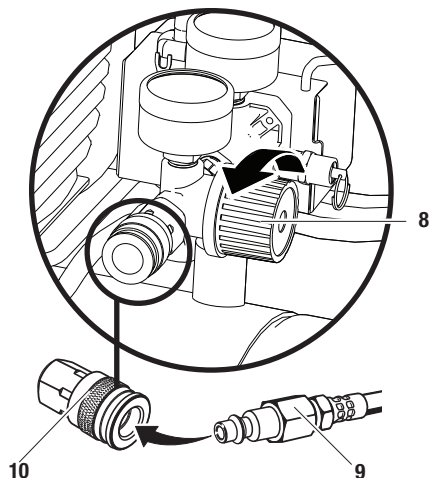
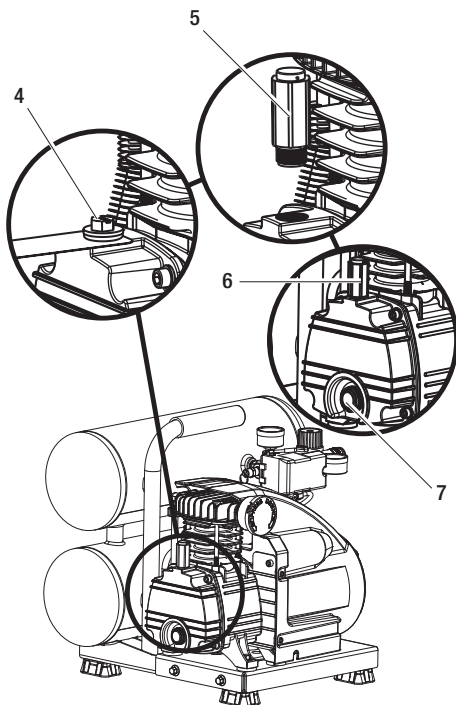











- Make sure the power to the air compressor is disconnected.
- Apply thread tape to the threaded connections of the hose (not included), and attach the quick connect to the hose using a wrench (not included).
- Rotate the pressure regulator knob (8) fully counterclockwise.
- Insert the hose adapter end of the air hose (9) into the female coupler end in the air compressor (10).



Pre-Operation (continued)

TOOL USAGE

= Continuous
 = Intermittent
 = Not Recommended

Tool	Inflation		Finishing Nailing		Framing/ Roofing	Bolting					
											
	Inflator	Brad Nailer	Stapler	Framing/Roofing Nailer	Impact Wrench	Heavy Duty 1/2 in. and 3/4 in. Impact Wrench		Air Ratchet			
Recommended Tool Use	<input type="radio"/>	<input type="radio"/>	<input type="radio"/>	<input type="radio"/>	<input type="radio"/>	<input type="radio"/>	<input type="radio"/>	<input type="radio"/>			
Tool	Cutting/Drilling			Surface Prep		Painting	HVLP Painting	Grease Gun			
											
	Air Hammer	Cut Off Tool	Drill/Impact Driver	Sander	Grinder	Paint Gun	Paint Gun	Grease Gun			
Recommended Tool Usage	<input type="radio"/>	<input type="radio"/>	<input type="radio"/>	<input type="radio"/>	<input type="radio"/>	<input type="radio"/>	<input type="radio"/>	<input type="radio"/>			

1 Preparing for start-up



WARNING: Risk of unsafe operation. Firmly grasp air hose in hand when installing or disconnecting to prevent hose whip.



WARNING: Risk of unsafe operation. Do not use damaged or worn accessories.



WARNING: Risk of bursting. Too much air pressure causes a hazardous risk of bursting. Check the manufacturer's maximum pressure rating for air tools and accessories. The regulator outlet pressure must never exceed the maximum pressure rating.



CAUTION: Risk of unsafe operation. Compressed air from the unit may contain water condensation and oil mist. Do not spray unfiltered air at an item that could be damaged by moisture. Some air tools and accessories may require filtered air. Read the instructions for the air tools and accessories.



NOTE: A regulator **MUST** be installed when using accessories rated at less than 150 psi. The hose or accessory will require a quick connect plug if the air outlet is equipped with a quick connect socket.

- Place the AUTO/OFF switch (1) to the off position.
- Close the drain valve (2).
- Visually inspect air lines and fittings for leaks.

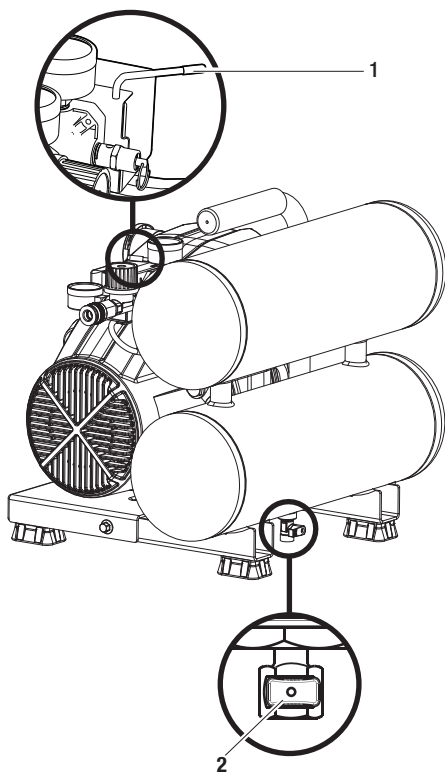

Operation (continued)

2 Starting the compressor



WARNING: Risk of bursting. If any unusual noise or vibration is noticed, stop the air compressor immediately and have it checked by a trained service technician.



NOTE: When using the regulator and other accessories, refer to the manufacturer's instructions.

- Plug the power cord into a proper receptacle.
- Turn the AUTO/OFF switch (1) to the AUTO position, and allow the tank pressure to build. The motor will stop when the tank pressure reaches "cut-out" pressure.
- Adjust the regulator (2) to a psi setting that is needed for your application - be sure it is within the safety standards required to perform the task.

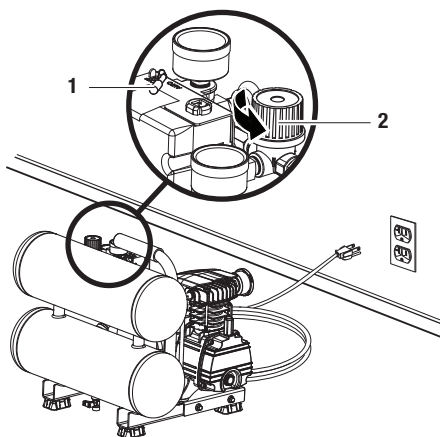

3 Checking the safety valve



DANGER: Do not tamper with the safety valve. Items loosened from this device could fly up and hit you. Failure to heed this warning could result in death or serious personal injury. The safety valve automatically releases air when the receiver pressure exceeds the preset maximum. Check the valve before each day of use by pulling the ring by hand.



WARNING: If air leaks after releasing the safety valve ring or if the valve is stuck, do not use the air compressor until the safety valve has been replaced. Using the air compressor in this condition could result in serious personal injury.

- Set the AUTO/OFF switch (1) to the AUTO position, and wait for the tank to fill. The compressor automatically shuts off when the pressure reaches the preset maximum.
- Set the AUTO/OFF switch (1) to the off position.
- Pull the ring on the safety valve (2) for 20 seconds to release the air.
- Release the ring. Air stops escaping at about 20 psi. If air continues to escape after releasing the safety valve ring, discontinue use and seek service before using the air compressor again.

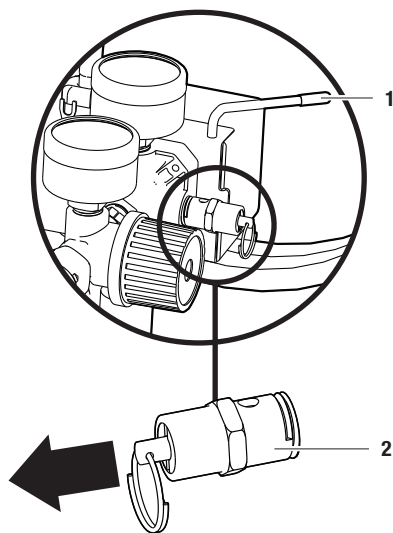

4 Running the air compressor



WARNING: Always ensure the switch is in the OFF position and regulator pressure gauge reads zero before changing air tools or disconnecting the hose from the air outlet. Failure to do so could result in possible serious personal injury.



WARNING: Your tool may require more air consumption than this air compressor is capable of providing. Check the tool manual to avoid damage to the tool or risk personal injury.



NOTE: Always use the minimum amount of air flow with the pressure regulator knob. Using a higher pressure than needed will drain air from the tank more rapidly and cause the unit to cycle on more frequently.

- Rotate the pressure regulator knob (1) to the desired line pressure. Turning the knob clockwise (+) increases air pressure at the outlet; turning counterclockwise (-) reduces air pressure at the outlet.
- If using an inflation accessory, control the amount of air flow with the pressure regulator knob (1). Turning the knob fully counterclockwise will completely stop the flow of air.
- When finished, always drain the tank and unplug the unit. Never leave the unit plugged in and/or running unattended.

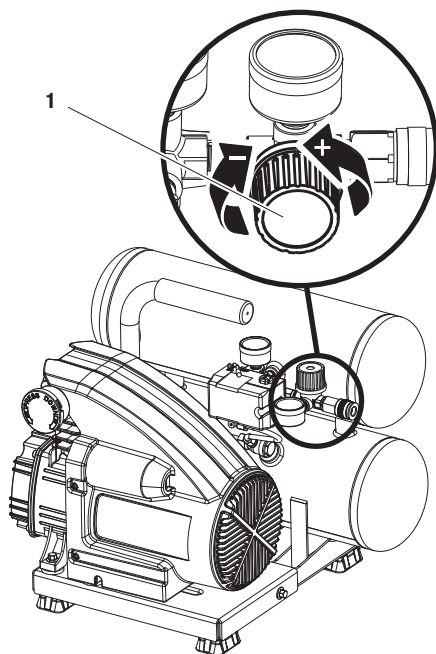

5 Draining the tank



WARNING: Risk of unsafe operation. Air tanks contain high pressure air. Keep face and other body parts away from the drain outlet. Use eye protection [ANSI Z87.1 (CAN/CSA Z94.3)] when draining, as debris can be kicked up into the face.



WARNING: Risk from noise. Use ear protection (ANSI S12.6 (S3.19), as air flow noise is loud when draining.



WARNING: Risk of bursting. Water will condense in the air tank. If not drained, water will corrode and weaken the air tank causing a risk of air tank rupture.



NOTE: All compressed air systems generate condensate that accumulates in any drain point (e.g., tanks, filter, after-coolers, dryers). This condensate contains lubricating oil and/or substances which may be regulated and must be disposed of in accordance with local, state, and federal laws and regulations.



NOTE: If the drain valve is plugged, release all air pressure. The valve can then be removed, cleaned, then reinstalled.



NOTE: Risk of property damage. Drained water from the air tank may contain oil and rust which can cause stains.

- Set the AUTO/OFF switch (1) to the off position.
- Slowly bleed the air from the compressor tank by pulling the safety valve to allow the pressure to escape from the tank until the pressure is approximately 20 psi.
- Drain water from the tank by opening the drain valve (2) on the bottom of the tank.
- After the water has been drained, close the drain valve. The air compressor can now be stored.

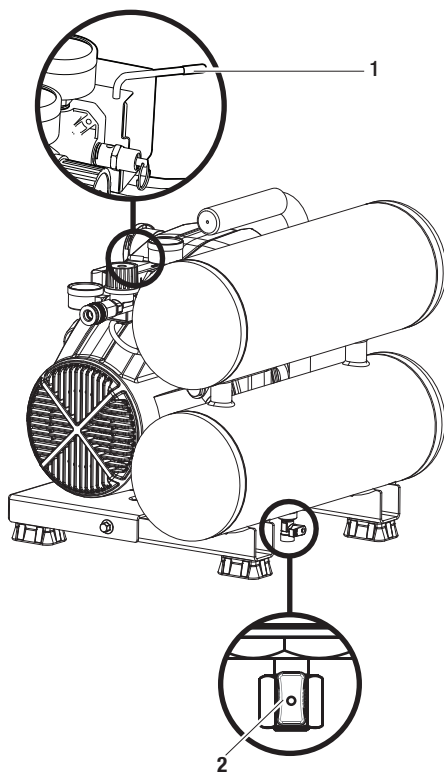

GENERAL MAINTENANCE

- Condensate forms in the tank when there is humidity in the air. Depending on the environmental conditions, drain the condensate daily and/or every hour. For instructions, see *Draining the tank* on page 16.
- The safety valve automatically releases air when the receiver pressure exceeds the preset maximum.
- Inspect the tank annually for rust, pin holes, or other imperfections that could cause it to become unsafe.
- Avoid using solvents when cleaning plastic parts. Most plastics are susceptible to damage from various types of commercial solvents and may be damaged by their use.
- Use clean cloths to remove dirt, dust, oil, grease, etc.

LUBRICATION

This compressor requires oil to be in the crank case in order to lubricate the pump for operation (see *REFILLING THE COMPRESSOR PUMP WITH OIL* on page 11). It is also necessary to change this oil after the first 10 hours of use and every 100 hours after that.

CLEANING THE AIR FILTER

From time to time, the air filter needs to be removed and cleaned.

- Turn the air compressor OFF (0).
- Unplug the air compressor.
- Unsnap the air filter cover (1) to remove.
- Remove the air filter (2) from the air filter housing (3).
- Blow compressed air through the air filter for 10-15 seconds using an approved OSHA nozzle.



WARNING: When servicing, use only identical Industrial Air Contractor replacement parts. Use of any other parts may create a hazard or cause product damage.



WARNING: Always release all pressure, disconnect from the power supply, and allow the unit to cool to the touch before cleaning or making repairs on the air compressor.



WARNING: Do not at any time let brake fluids, gasoline, petroleum-based products, penetrating oils, etc., come in contact with plastic parts. Chemicals can damage, weaken or destroy plastic which may result in serious personal injury. Electric tools used on fiberglass material, wallboard, spackling compounds, or plaster are subject to accelerated wear and possible premature failure because the fiberglass chips and grindings are highly abrasive to bearings, brushes, commutators, etc. Consequently, we do not recommend using this tool for extended work on these types of materials. However, if you do work with any of these materials, it is extremely important to clean the tool using compressed air.

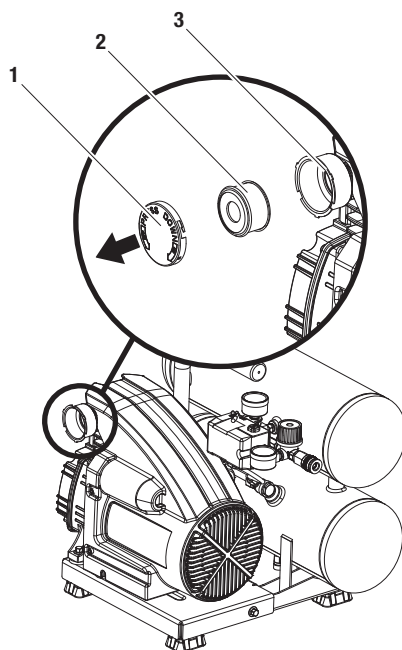

Maintenance (continued)

CHANGING THE OIL

When changing the pump oil, be sure to do the following:

- Turn the unit off and unplug the power cord from the receptacle.
- Allow the compressor time to cool if it has been in operation.
- Open the drain valve (6) to bleed all the air from the tank.
- Close the drain valve (6).
- Remove the oil fill cap/breather (4) on the pump.
- Remove the sight glass (5) with a box-end wrench or socket. Drain the oil into a suitable container and dispose of properly. The compressor may need to be tipped slightly towards the drain hole to allow all of the oil to drain.
- Reattach the sight glass (5). Torque the sight glass 10-12 in.-lbs. when re-assembling. Be sure the gasket is between the sight glass and the pump crankcase.
- Refill the compressor pump with an air compressor oil, such as SAE-30 non-detergent, Semi Synthetic oil, at slow intervals until the oil reaches the center of the red circle in the sight glass (5). Use a SAE-10 during extreme winter conditions.

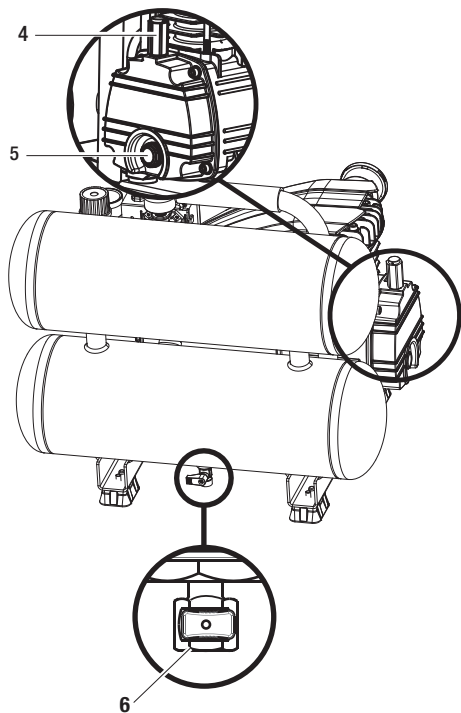

Care and Cleaning

- Drain the air tank of moisture after operation.
- When not in use, store the compressor in a cool, dry place.
- Disconnect the air hose and hang open ends down to allow any moisture to drain.
- Protect the electrical cord and air hose from damage (such as being stepped on or run over). Wind them loosely around the compressor handle.

Troubleshooting

Problem	Possible Cause	Solution
The compressor does not run.	<input type="checkbox"/> There is a loss of power or the motor is overheated.	<input type="checkbox"/> Check for proper use of extension cord.
	<input type="checkbox"/> There is no power to the unit.	<input type="checkbox"/> Check to be sure the unit is plugged in.
	<input type="checkbox"/> The circuit breaker has tripped or a fuse has blown at the main power source.	<input type="checkbox"/> Check the fuse/breaker.
	<input type="checkbox"/> The thermal overload protector is actuated.	<input type="checkbox"/> Turn the air compressor OFF (0).
		<input type="checkbox"/> Unplug the air compressor and wait until the compressor cools down.
		<input type="checkbox"/> Plug the air compressor into an approved outlet.
	<input type="checkbox"/> Turn the air compressor AUTO (1).	
<input type="checkbox"/> The pressure switch is bad.	<input type="checkbox"/> Bring the compressor to a service center.	
<input type="checkbox"/> The compressor has reached automatic shutoff pressure.	<input type="checkbox"/> Release the air from the tank until the compressor restarts automatically.	
The motor hums while running slowly, or it does not run at all.	<input type="checkbox"/> There is low voltage from the power source.	<input type="checkbox"/> Call an electrician.
	<input type="checkbox"/> The wrong gauge wire or length of extension cord is being used.	<input type="checkbox"/> Check for proper gauge wire and cord length.
	<input type="checkbox"/> There is a shorted or open motor wiring.	<input type="checkbox"/> Bring the compressor to a service center.
	<input type="checkbox"/> There is a defective check valve or unloader.	<input type="checkbox"/> Bring the compressor to a service center.
The fuses blow or circuit breaker trips repeatedly.	<input type="checkbox"/> The incorrect fuse type is being used.	<input type="checkbox"/> Check for the proper fuse.
		<input type="checkbox"/> Use a time-delay fuse. Disconnect other electrical appliances from the circuit or operate the compressor on its own branch circuit.
	<input type="checkbox"/> The wrong gauge wire or length of extension cord is used.	<input type="checkbox"/> Check for the proper gauge wire and cord length.
<input type="checkbox"/> There is a defective check valve or unloader.	<input type="checkbox"/> Bring the compressor to a service center.	

Troubleshooting (continued)

Problem	Possible Cause	Solution
The thermal overload protector cuts out repeatedly.	<input type="checkbox"/> There is low voltage from the power source.	<input type="checkbox"/> Call an electrician.
	<input type="checkbox"/> There is a lack of proper ventilation, or the room temperature is too high.	<input type="checkbox"/> Move the compressor to a well-ventilated area.
	<input type="checkbox"/> The wrong gauge wire or length of extension cord is being used.	<input type="checkbox"/> Check for proper gauge wire and cord length.
The air receiver pressure drops when the compressor shuts off.	<input type="checkbox"/> The connections (fittings, tubing, etc.) are loose and leaking.	<input type="checkbox"/> Check all connections with a soap and water solution and tighten.
	<input type="checkbox"/> The drain valve is loose or open.	<input type="checkbox"/> Tighten the drain valve.
	<input type="checkbox"/> The check valve is leaking.	<input type="checkbox"/> Bring the compressor to a service center.
There is excessive moisture in the discharge air.	<input type="checkbox"/> There is excessive water in the air tank.	<input type="checkbox"/> Drain the tank.
	<input type="checkbox"/> The compressor is working under a high humidity environment.	<input type="checkbox"/> Move the compressor to an area of less humidity; use an air line filter.
The compressor continuously runs.	<input type="checkbox"/> The pressure switch is defective.	<input type="checkbox"/> Bring the compressor to a service center.
	<input type="checkbox"/> An excessive amount of air is being used.	<input type="checkbox"/> Decrease the air usage; the compressor is not large enough for the tool's requirement.
The air output is lower than normal.	<input type="checkbox"/> The inlet valves are broken.	<input type="checkbox"/> Bring the compressor to a service center.
	<input type="checkbox"/> The connections (fittings, tubing, etc.) are loose and leaking.	<input type="checkbox"/> Tighten the connections.

Service Parts

C042I, AIR COMPRESSOR

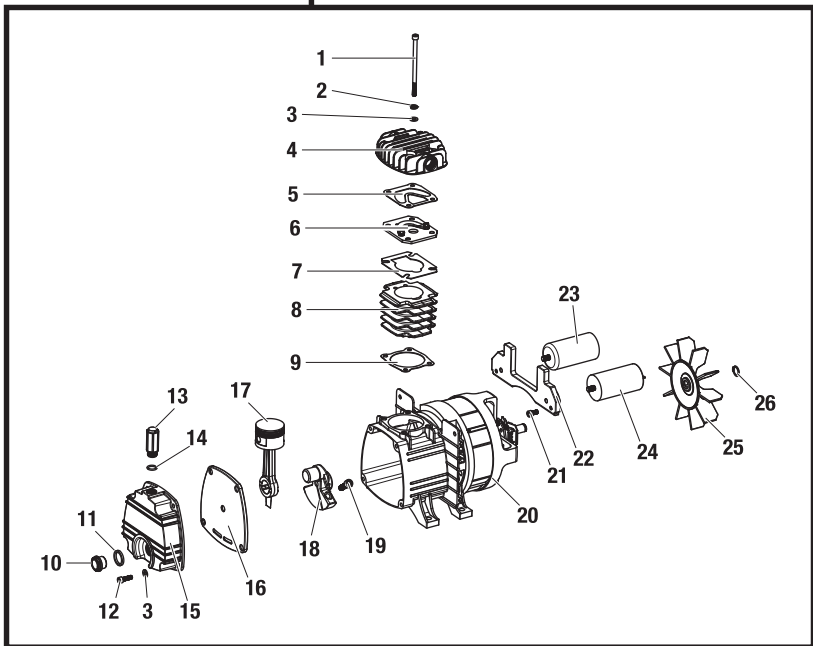
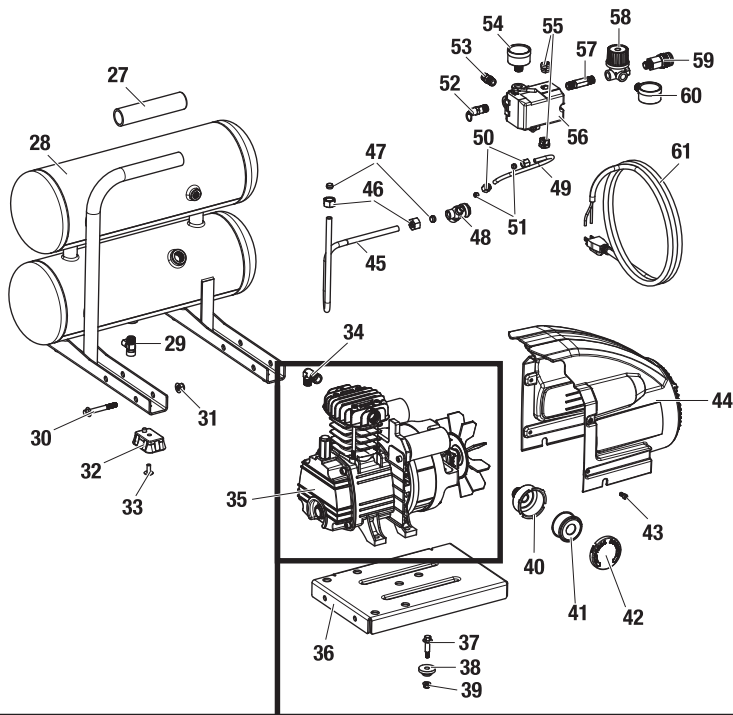

Service Parts (continued)

C042I, AIR COMPRESSOR

Item Number	Description	Quantity	Part Number	Kit Number
1	Screw, SHC M6 X 1.0 X 107 mm	4	E108461	4
2	Washer, Lock M6	4		4
3	Washer, Flat M6	8		4
4	Head, Cylinder	1	E102728	4
5	Gasket, Piston Head	1		1 & 4
6	Assembly, Valve Plate	1		4
7	Gasket, Valve Plate to Cylinder	1		1 & 4
8	Cylinder	1	E108433	4
9	Gasket, Cylinder	1		1 & 4
10	Gauge, Oil Sight	1		3 & 4
11	Gasket, Oil Sight	1		3 & 4
12	Screw, SHC M6 X 1.0 X 20 mm	4		4
13	Cap, Oil Fill	1		2 & 4
14	O-ring, Oil Fill Cap	1		2 & 4
15	Cover, Crankcase	1	E108530	4
16	Baffle, Crankcase	1		1 & 4
17	Assembly, Piston	1	E107755	4
18	Eccentric	1	E107962	4
19	Screw, SHC M8 X 1.25 X 25 mm	1		4
20	Crankcase	1		4
21	Screw, SHC M6 X 1.0 X 12 mm	2		4
22	Bracket, Capacitor	1	E108370	4
23	Capacitor, Starting	1	E106415	4
24	Capacitor, Running	1	E106416	4
25	Fan, Radial	1	E109064	4
26	Ring, External Retaining	1	E100979	4
27	Grip, Handle	1	E106495	
28	Weldment, Tank	1		
29	Valve, Drain	1	E107047	
30	Screw, HFH M8 X 1.25 X 60 mm	3		
31	Nut, Hex Flange M8 X 1.25 Nylon Insert	3		
32	Isolator, Unit	4	E108422	
33	Screw, Pan Head Washer M6 X 1.0 X 16 mm	4		
34	Fitting, Elbow 3/8 NPT X 3/8 Compression	1	E109007	

Service Parts (continued)

C042I, AIR COMPRESSOR

Item Number	Description	Quantity	Part Number	Kit Number
35	Assembly, L2 Pump/Motor with LH Exhaust	1		4
36	Saddle, Pump Mounting	1	E109758	
37	Screw, HFH Shoulder M6 X 1.0 X 22 mm	4		9
38	Isolator, Pump	4		8
39	Nut Hex Flange M6 X 1.0 Nylon Insert	4		9
40	Base, Air Filter	1		5
41	Element, Air Filter	1		5
42	Cover, Air Filter	1		5
43	Screw, SHC M5 X 0.8 X 12 mm	4		
44	Shroud	1	E107879	
45	Tube, 3/8 in. Copper Outlet	1		6
46	Nut, 3/8 in. Compression	2		6
47	Ferrule, 3/8 in.	2		6
48	Valve, Check Top	1	E101208	
49	Tube, 1/4 in. Copper Pressure Relief	1		7
50	Nut, 1/4 in. Compression	2		7
51	Ferrule, 1/4 in.	2		7
52	Valve, Safety	1	E102611	
53	Nipple, 1/4 NPT X 32 mm	1		
54	Gauge, Pressure 38 mm with 135 psi R/L	1	E103363	
55	Restraint, Power Cord	2	E100594	
56	Switch, Pressure 135 psi	1	E102751	
57	Nipple, 1/4 NPT X 50 mm	1		
58	Regulator, 3 Port 1/4 NPT	1	E107300	
59	Quick Connect Coupler	1	E107373	
60	Gauge, Pressure 38 mm with 135 psi R/L	1	E108549	
61	Cord, Power 14/3 AWG Type SJT 6 ft. long	1	E100101	



NOTE: Any part/kit number field without a number is not available. Descriptions are provided for reference only. The Kit Number column represents that the part being offered is available in a kit.

Service Parts (continued)

KITS

Kit Number	Description	Ref. Number	Part Number
1	Kit, Gasket	5, 7, 9, 16	E109152
2	Kit, Oil Fill Cap	13-14	E100087
3	Kit, Oil Sight Gauge	10-11	E109153
4	Kit, L2 Motor/Pump Assembly w/LH Exhaust	1-26, 35	E109763
5	Kit, Air Filter	40-42	E100435
6	Kit, 3/8 in. Copper Outlet Tube	45-47	E109154
7	Kit, 3/8 in. Copper Pressure Relief Tube	49-51	E109155
8	Kit, Pump Isolator (4 Pack)	38	E109156
9	Kit, Pump Mounting Hardware (1 Set)	37, 39	E109157



NOTE: Any part/kit number field without a number is not available. Descriptions are provided for reference only. The Kit Number column represents that the part being offered is available in a kit.

IndustrialAirTM

C O N T R A C T O R .[®]



Questions, problems, missing parts? Before returning to the store, call Customer Service
8 a.m. - 6 p.m., EST, Monday - Friday

PRODUCT SERVICE:
888-895-4549

industrialaircontractor.com